

Seminar

Expo

Training

Function

Board meeting

Trade show

Meeting

Road show

Team building

Convention

Sales training

*Think about
your programme,
we'll do the rest*

Conference
Information

Judy Bain
Events Manager
Capital Gateway Motor Inn
Email :- jb.capital.gateway@xtra.co.nz
www.capitalgateway.co.nz



Capital Gateway Motor Inn

Thank you for your interest in our conference services.

Our aim is to provide you with complete and seamless service so that your gathering runs smoothly allowing you to concentrate on your business objectives.

There are a number of benefits in choosing Capital Gateway:

Location: We are handy to Wellington City, Porirua and the Hutt Valley, just 10 minutes in fact

Easy to find: Take the Newlands exit off SH1 at the top of Ngauranga Gorge

Parking: Plenty of off street parking and it is all free of charge

Wifi: Free unlimited Wifi is available in all our function rooms and motel rooms

Choice: Three quiet, modern conference rooms

Catering: A variety of excellent menus we will tailor to suit your particular needs. We also provide a full a-la-carte restaurant service for dinner and breakfast

Fresh air: During your breaks there's the outdoors area, free of city chaos, to stretch the legs.

Bar Service: Your choice of conference room service or use our guest bar

Accommodation: We also offer full accommodation for out-of-town colleagues

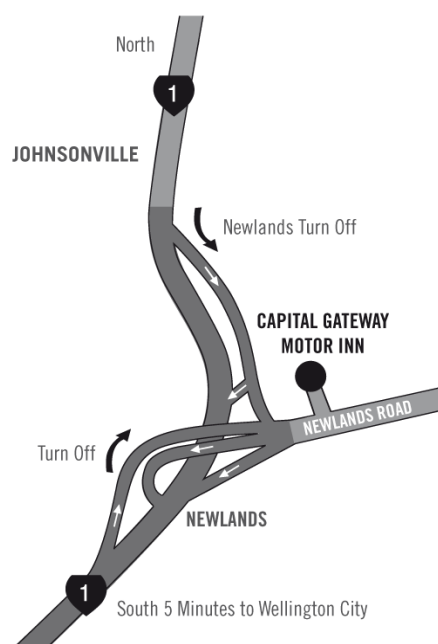

Think about your programme, we'll do the rest

Capital Gateway Motor Inn

TUDOR ROOM

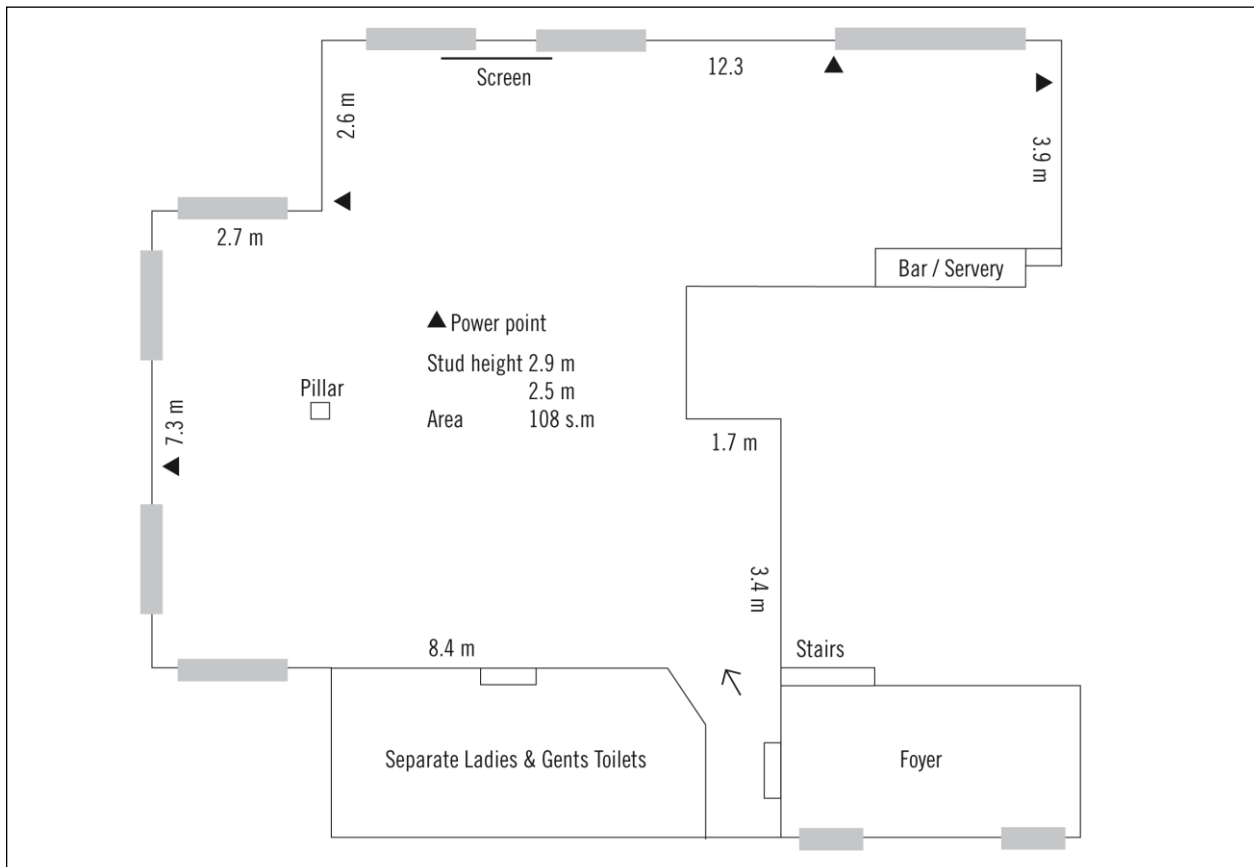

SEATING ARRANGEMENT OPTIONS

Theatre style	70	Cafe	45
Boardroom	20	Dining	60
U shape	28		

FEATURES

- Plenty of natural light
- Natural ventilation
- Quiet
- Large foyer and break-out areas
- Heat Pump / Air conditioning
- Own PA system
- Own bar, servery
- Own stair access and toilets
- Telephone

Included in the hire charges are large built-in projection screen for data show, PA system, lectern and flipchart board. We also set up the room to your specifications and supply chilled water and wrapped mints.

Think about your programme, we'll do the rest

EDWARD ROOM

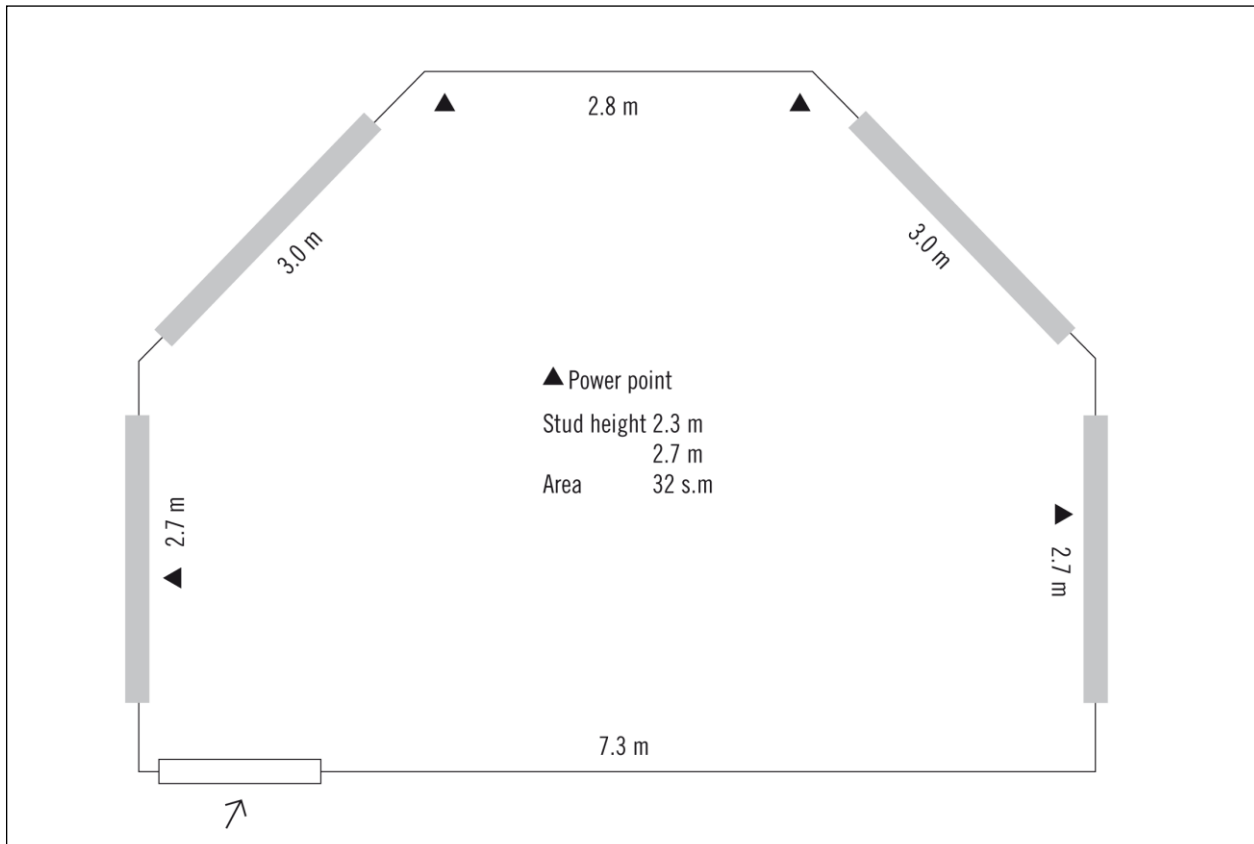

SEATING ARRANGEMENT OPTIONS

Theatre style	25	Classroom	16
Boardroom	18	Dining	25
U shape	14		

FEATURES

- Plenty of natural light
- Natural ventilation
- Ground level access
- Quiet

Included in the hire charge are a lectern and flipchart board. We also set up the room to your specifications and supply chilled water and wrapped mints.

Think about your programme, we'll do the rest

ALEX ROOM

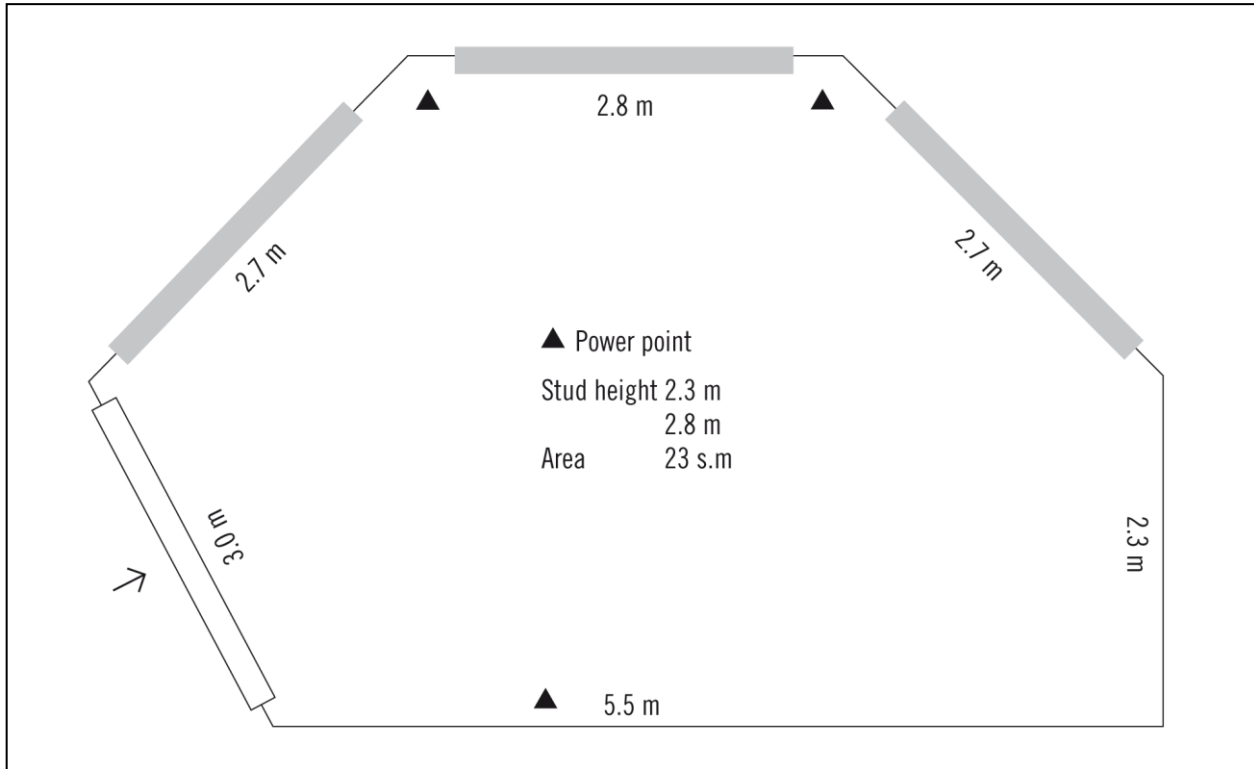

SEATING ARRANGEMENT OPTIONS

Theatre style	20	Classroom	12
Boardroom	12	Dining	20
U shape	10		

FEATURES

- Plenty of natural light
- Natural ventilation
- Ground level access
- Quiet

Included in the hire charge are a lectern and flipchart board. We also set up the room to your specifications and supply chilled water and wrapped mints.

Think about your programme, we'll do the rest

CONFERENCE EQUIPMENT

You are most welcome to bring your own conference equipment. However should you need us to organise any, this form might be helpful. It can also be downloaded from our website.

	Cost per day	Day 1	Day 2	Day 3	Day 4	Day 5	Total
Lectern	Complimentary						
Flip chart board	Complimentary						
Flip chart paper	\$20						
Whiteboard -portable & pens	\$20						
32" LCD TV	\$150						
Video or DVD	\$35						
Data projector *	\$100						
Flat TV screen	\$60						
Data Screen - portable	\$20						

* Electronic equipment is hired in and is subject to availability. To avoid disappointment please advise us of your requirements as early as possible.

We are happy to arrange any other equipment not shown here.

Think about your programme, we'll do the rest

CONFERENCE CATERING

Conference Day Catering Package

We have a wide range of catering options available, and these can be emailed or posted to you upon request.

Our Conference Day Catering Package is a popular catering option.

\$35.00 per person (Conference Day Catering Package)

Tea and Coffee

Just tea and coffee \$3.50 per person

With freshly baked muffins or scones or cookies \$7.50 per person

If you require savouries, croissants, sandwiches, cakes or other light food options let us know.

Other Menus

We can offer you a range of luncheon and finger food menus to suit your occasion and budget. Again, discuss with us what you would like.

Dinners

We have a full service a-la-carte restaurant for evening dining. We can also offer our full restaurant service in a private dining room. Set menu dinners are also available.

Bar Services

Capital Gateway Motor Inn offers full bar service. You are welcome to use our guest's bar or we can provide refreshments in the privacy of any of the conference rooms.

Think about your programme, we'll do the rest

Capital Gateway Motor Inn

CONFERENCE BOOKING

You may make your booking by telephone or email. Alternatively you can mail or fax this booking form which can also be downloaded from our website. We will confirm your booking.

COMPANY
ADDRESS
CONTACT NAME
TITLE
TELEPHONE
EMAIL
BOOKING DATE/S	IN..... OUT
CONFERENCE ROOM CHOICE
NUMBER OF PEOPLE
SEATING LAYOUT
CATERING REQUIREMENTS
EQUIPMENT REQUIREMENTS	If faxing or mailing this booking please also send the completed Conference Equipment sheet.
BAR REQUIREMENTS
ACCOMMODATION (If required)	How many rooms IN OUT
OTHER

Address: 1 Newlands Road, Newlands, Wellington

Postal: P O Box 83105, Johnsonville, Wellington 6440

Telephone: 04 478 7812; 0800 4 22748 Fax: 04 478 1342

Email: capitalgateway@xtra.co.nz

Website: www.capitalgateway.co.nz

Think about your programme, we'll do the rest